

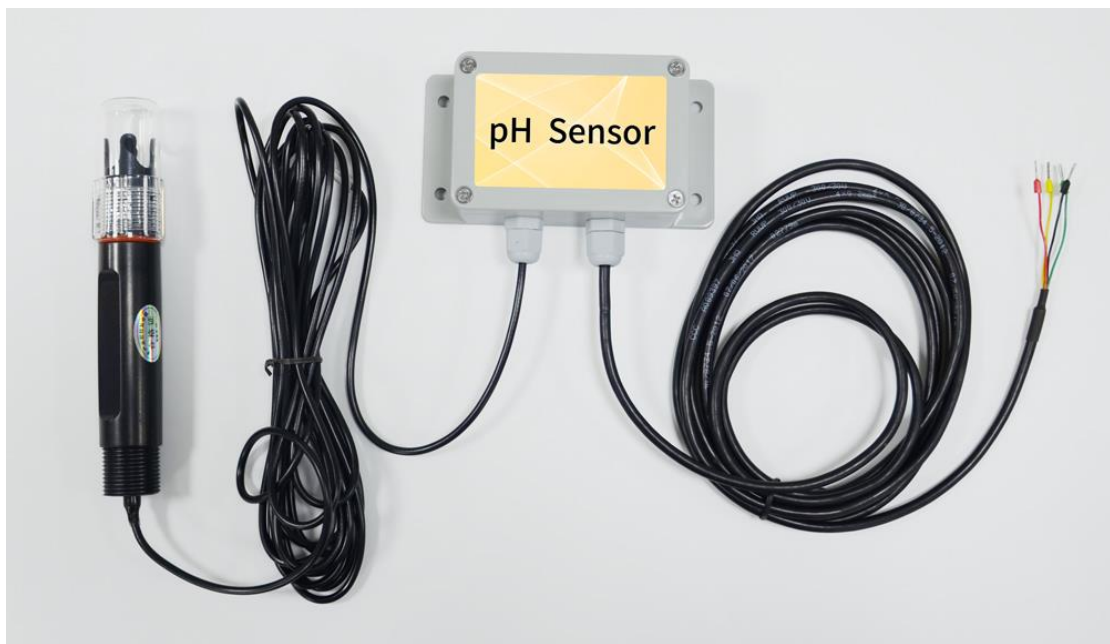

# PH transmitter Introduce



**Type NO.: PH-RD-SOR**



## 1. Product Introduce

The PH-RD-SOR sensor is a good solution to the traditional measurement of pH value, professional calibration instrument, cumbersome calibration, difficult integration, high power consumption, high price, difficult to carry, etc. It is an intelligent upgrade product of industrial acidity meter, which can be used for water quality. The sewage pH value is continuously measured and controlled. The device is suitable for urban sewage treatment plants, chemical industry, printing and dyeing, papermaking, pharmaceutical, electroplating and environmental protection.



We also can Equip with a water storage tank, used when measuring soil, can be buried in the soil for a long time, online monitoring.

## 2. Product Features

1. Internally use axial capacitance filtering, 100M resistor to increase impedance and enhance stability
2. High integration, small size, low power consumption and convenient carrying;
3. Realize low cost, low price and high performance;
4. High integration, long life, convenience and high reliability;
- 5, up to four isolation, can resist the complex interference situation on site, waterproof rating IP68
- 6, the electrode uses high-quality low-noise cable, can make the signal output length of more than 20 meters
- 7, one-piece, split, split BNC connector three shapes, suitable for a variety of installation environments

## 3. Product application

Applicable to water-saving agricultural irrigation, greenhouses, flowers and vegetables, grassland



pastures, rapid water quality testing, plant cultivation, scientific experiments and other fields.

## 4. Product Parameter

### (1) Technical Parameters

- Measuring range: pH: 0 ~ 14 pH
- Accuracy:  $\pm 0.02\text{pH}$ ;  $\pm 1\text{mV}$
- Resolution: 0.01pH; 1mV
- Stability:  $\leq 0.02\text{pH}/24\text{ hours}$ ;  $\leq 3\text{mV}/24\text{ hours}$
- Output signal:

A: Voltage signal (0~2V, 0~2.5V, 0~5V, 0~10V, one of four)

B: 4 to 20 mA (current loop)

C: RS485 (standard Modbus-RTU protocol, device default address: 01)

- Supply voltage: 5 ~ 24V DC (when the output signal is 0 ~ 2V, 0 ~ 2.5V, RS485)
- 12~24V DC (when the output signal is 0~5V, 0~10V, 4~20mA) (can be customized 3.3 ~ 5V DC)
- Working environment: temperature 0 ~ 60 ° C;
- Humidity  $\leq 85\%$  RH
- Power consumption:  $\leq 0.5\text{W}$
- Impedance requirements for current signals

Supply voltage	9V	12V	20V	24V
Maximum impedance	125 $\Omega$	250 $\Omega$	500 $\Omega$	>500 $\Omega$

## 5. Product size

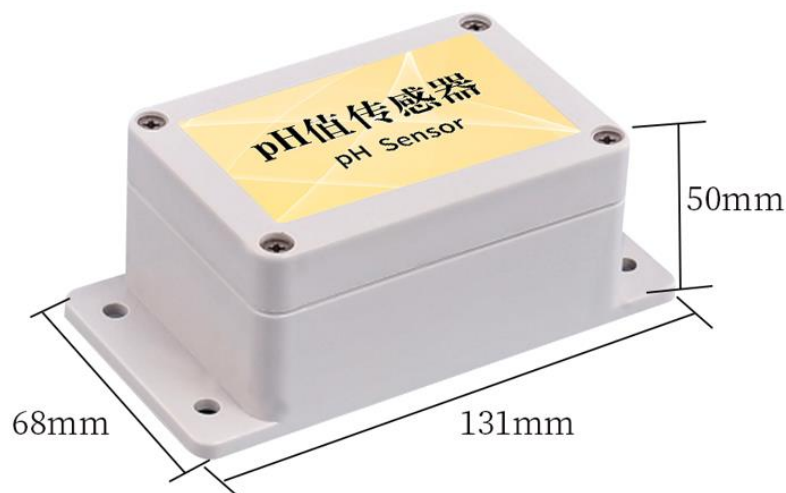

➤ Electrode

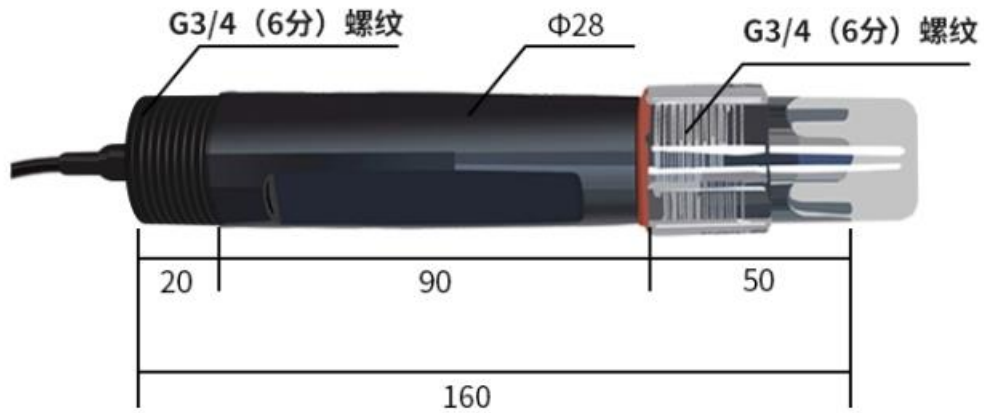

PH electrode

**6. Line connection diagram**

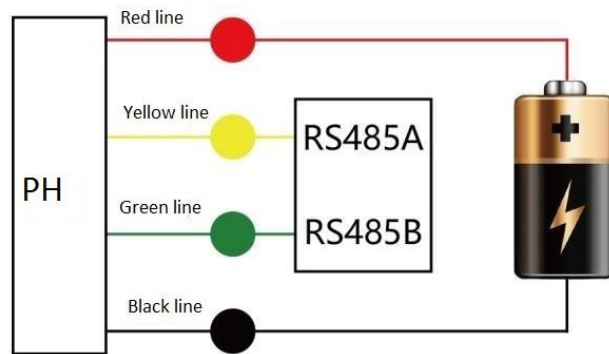

(RS485)

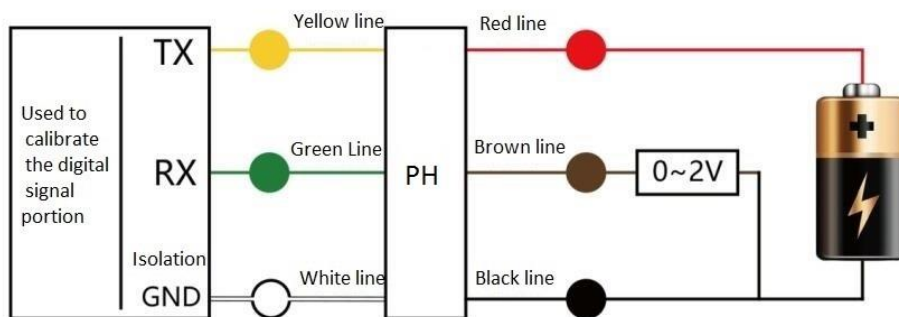

(0~2V、0~5V、0~10V)

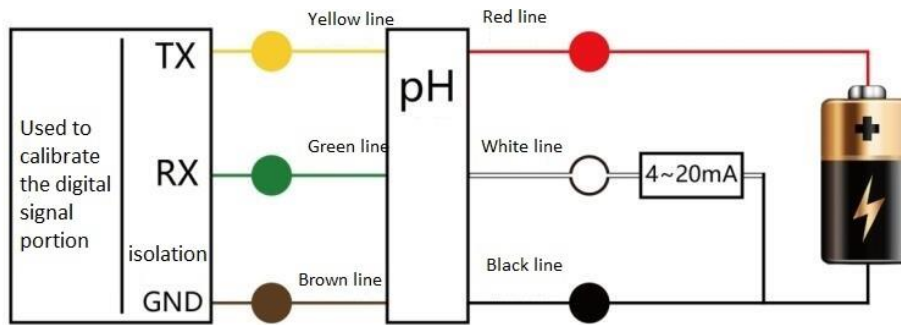

(4~20mA)

## 7. Data conversion method

The PH sensor has good linear characteristics. The following is a typical calibration formula.

V: voltage value collected by the collector, unit: V;

A: Current value collected by the collector, unit: mA

output signal	pH conversion method
0 ~ 2V DC	$PH = 7 * V$
0 ~ 5V DC	$PH = 2.8 * V$
0 ~ 10V DC	$PH = 1.4 * V$
4 ~ 20mA	$PH = 0.875 * A - 3.5$

RS485 signal (default address 01):

Standard Modbus-RTU protocol, baud rate: 9600; check digit: none; data bit: 8; stop bit: 1

1. modify the address, for example: change the address of the transmitter with address 1 to 2, host → slave

Original address	Function code	Reserved 1	Reserved 2	Reserved 3	new address	CRC16 low	CRC16 high
0X01	0X06	0X00	0X00	0X00	0X02	0X08	0X0B

If the transmitter receives correctly, return the following data, slave → host

Original address	Function code	Data length	Reserved 1	new address	CRC16 low	CRC16 high
0X01	0X06	0X02	0X00	0X02	0X39	0X49

Remark: If you forget the original address of the sensor, you can use the broadcast address 0XFE



instead. When using 0XFE, the host can only be connected to one slave, and the return address is still the original address, which can be used as the address query method.

2. Query data

Query the data of the transmitter (address 1) (PH value), host → slave

Address	Function code	Start register address high	Start register address low	Register length high	Register length low	CRC16 low	CRC16 high
0X01	0X03	0X00	0X00	0X00	0X01	0X84	0X0A

If the transmitter receives correctly, return the following data, slave → host

Address	Function code	Data length	Register 0 data high	Register 0 data low	CRC16 low	CRC16 high
0X01	0X03	0X02	0X02	0XAE	0x38	0X98
			PH Value			

Data representation method:

Data representation: Convert data to decimal ÷100

The above data indicates that the pH value is 6.86

3.PH value offset calibration

Data description	Data length	Register address	Type of data	Read and write type	Note
PH offset value	1	0X0054	Integer	Read/Write	Numerical accumulation, 0X0000: Restore to the initial value

For example add 0.1 to the sensors address 01 to the present value, send the following instruction

Address	Function code	Register data high	Register data low	PH offset value		CRC16 low	CRC16 high
0X03	0X06	0X00	0X54	00	0A	0x49	0XFF

If success, feed back : 03 06 00 54 00 0A 49 FF.

## 8. Installation method

Please pay attention that do not put the electrode directly into the HCL . Use an electrode mounting bracket or a flow cup. Be sure to use a raw material tape (3/4 thread) for waterproof sealing before installation to prevent HCL from entering the PH electrode, causing the PH electrode cable to be shorted.



## 9. Instructions

1. Sampling: According to the sampling requirements, take a representative water sample.
2. Determine the pH of the water sample: first rinse the electrode with distilled water, then rinse with water sample, then immerse the electrode in the sample, carefully shake the test cup or stir to accelerate the electrode balance, let stand, and record the pH when the reading is stable. value.
3. If it is not convenient to sample, the electrode can also be placed in the solution to be tested, and the output data can be read. After a period of time, the electrode should be taken out and cleaned.

## 10. Calibration method

The pH sensor has been rigorously calibrated at the factory, so the user does not have to perform a



second calibration. If the sensor has an error due to electrodes or other reasons, the calibration can be performed by the following method.

After connecting the wires according to the wiring diagram in Section 6, the calibration steps are as follows:

(1) Put the electrode into the following PH standard calibration solution, and then send the instruction to the sensor:

(2) PH=9.18 electrode calibration instruction FE 55 55 55 55 0A A7 42, If success return: 0x03, If failure return: 0x04 ( need around 3-5 minutes to return)

(3) PH=6.86 electrode calibration instruction FE 55 55 55 55 0B 66 82 , If success return: 0x05, If failure return: 0x06 ( need around 3-5 minutes to return)

(4) PH=4.00 electrode calibration instruction FE 55 55 55 55 0C 27 40, If success return: 0x07 , If failure return: 0x08 ( need around 3-5 minutes to return)

After the above three steps are completed, the calibration is successful. The advantage of the three-point calibration compared to the two-point calibration is that the electrodes are separately calibrated in the acid and alkali parts to achieve accurate calibration of the full scale, making the measurement data more accurate.

## **11. Precautions for use**

1. In order to ensure that the electrode is correctly measured on the pipeline, the data gap between the measuring cells should be avoided to cause data misalignment;
2. Please check whether the packaging is intact, and check whether the product model is consistent with the selection;
3. Do not electrify the wiring, the wiring is completed, and the power can be turned on after checking.
4. Do not arbitrarily change the components or wires that have been soldered at the time of shipment;
5. The sensor is a precision device, please do not disassemble it yourself, use sharp objects or corrosive liquid to touch the sensor surface to avoid damage to the product;